

Prop Guard

NO EXCUSES

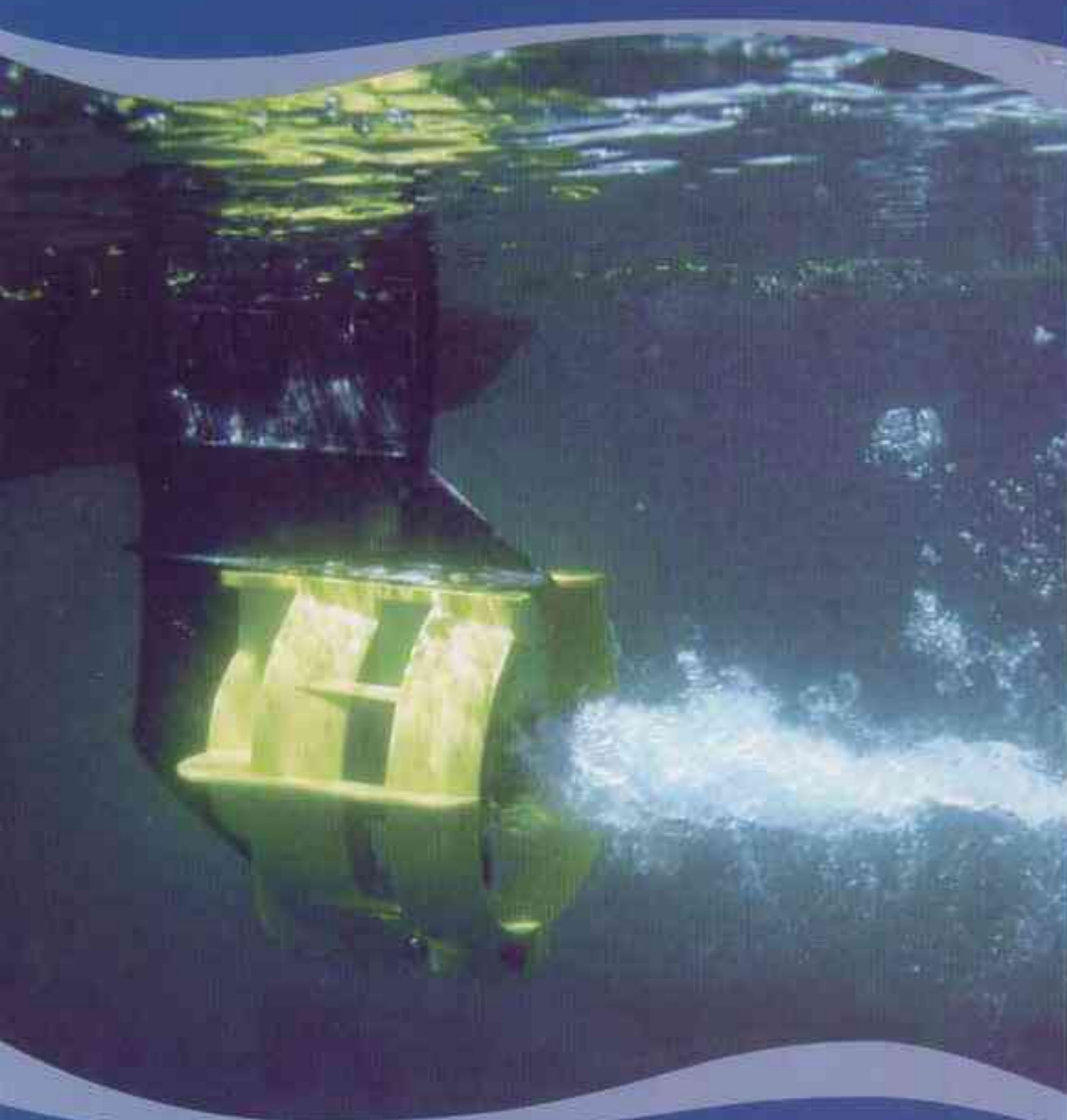

can you afford not to?

CZECH Marine s.r.o. (1)
 Dubičné 93
 373 71 České Budějovice - Rudolfov
 Tel.: +420 602 494 240 www.czmarine.cz
 GPS: N48°59'034" / E14°32'028"
 DIČ: CZ482 45 135

CZECH Marine s.r.o. (1)
 Dubičné 93
 373 71 České Budějovice - Rudolfov
 Tel.: +420 602 494 240 www.czmarine.cz
 GPS: N48°59'034" / E14°32'028"
 DIČ: CZ482 45 135

CZECH Marine s.r.o. (1)
 Dubičné 93
 373 71 České Budějovice - Rudolfov
 Tel.: +420 602 494 240 www.czmarine.cz
 GPS: N48°59'034" / E14°32'028"
 DIČ: CZ482 45 135

CZECH Marine s.r.o. (1)
 Dubičné 93
 373 71 České Budějovice - Rudolfov
 Tel.: +420 602 494 240 www.czmarine.cz
 GPS: N48°59'034" / E14°32'028"
 DIČ: CZ482 45 135

MEASUREMENT GUIDE

To obtain and select the Prop Guard™ for your boat you must measure the distance from your anti-cavitation plate to the centre of your propeller shaft. Refer to Fig. A.

Prop Guard™ Application Chart

Cavitation plate to prop shaft measurement	Propguard Model	Maximum Propeller Size
110mm - 140mm (4.25" - 5.5")	9XP 9" Prop Guard™	5/9 HP 9" propeller 99/20
145mm - 154mm (5.75" - 6.0")	11" Prop Guard™	11" propeller 25/30
155mm - 165mm (6.0" - 6.5")	13" Prop Guard™	13" propeller 40/65
166mm - 190mm (6.5" - 7.5")	14" Prop Guard™	14" propeller 70/100
200mm - 215mm (8.0" - 8.5")	16" Prop Guard™	16" propeller 110/150

To obtain optimal performance out of your motor with the Prop Guard™ installed, you may need to change your propeller diameter to the maximum propeller size as above

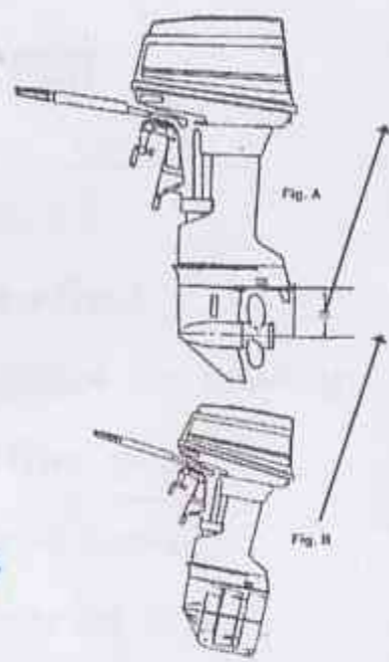

The closer the prop blades are to the guard rings, the better the performance, handling and reduction in drag. Your motor will also have to be trimmed to a setting of optimal performance. Refer to Fig. B.

Be sure the Prop Guard™ you purchase is the correct size. Place it on your motor with Grip Clamps first and **CHECK YOUR CLEARANCES BEFORE DRILLING HOLES AND MOUNTING.**

Manufacturer will not warrant, and accept back for credit, your Prop Guard™ should you drill into Prop Guard™ and find you have purchased the wrong size.

Above all, please take your time in measuring and selecting the proper size Prop Guard™.

Consult your Prop Guard Dealer if further information is required.

READ BEFORE PURCHASING OR INSTALLING PROP GUARD®!

To obtain and select your Prop Guard® please select from chart.

Refer to Fig. A

9-XP Prop Guard® (Safety White) fits / 5hp to 9hp

9" Prop Guard® (Safety Yellow) fits / 9.9hp to 20hp

11" Prop Guard® (Safety Orange) fits / 25hp to 35hp

13" Prop Guard® (Safety Blue) fits / 40hp to 65hp

14" Prop Guard® (Safety Red) fits / 70hp to 100hp

**16" Prop Guard® (Safety White) fits/ 110hp to 350hp
(All Stern Drives & Volvo Dual)**

To obtain optimal performance out of your motor with the Prop Guard® installed, you may need to change your propeller diameter...9" Prop Guard® up to 8.5" prop, 11" Prop Guard® up to 10.5" prop, 14" Prop Guard® up to 13.5" prop and 16" Prop Guard® up to 15.5" prop. The closer the prop blades are to the Prop Guard® rings, will optimize your performance, handling and decrease drag. Your motor will also have to be trimmed to a setting of optimal performance. Refer to Fig. B.

Be sure the Prop Guard® you purchase is the correct size. Place it on your motor with Grip Clamps first and **CHECK YOUR CLEARANCES BEFORE DRILLING HOLES AND MOUNTING.**

Manufacturer will not warrant your Prop Guard® should you drill into Prop Guard® and find you have purchased the wrong size Prop Guard®.

Above all, please take your time in measuring and selecting the proper size Prop Guard®.

Consult your Marine Dealer or bring your motor by for an inspection for proper size.

You're never in a hurry!

Big Foot & High Thrust go, to next size up HP range.

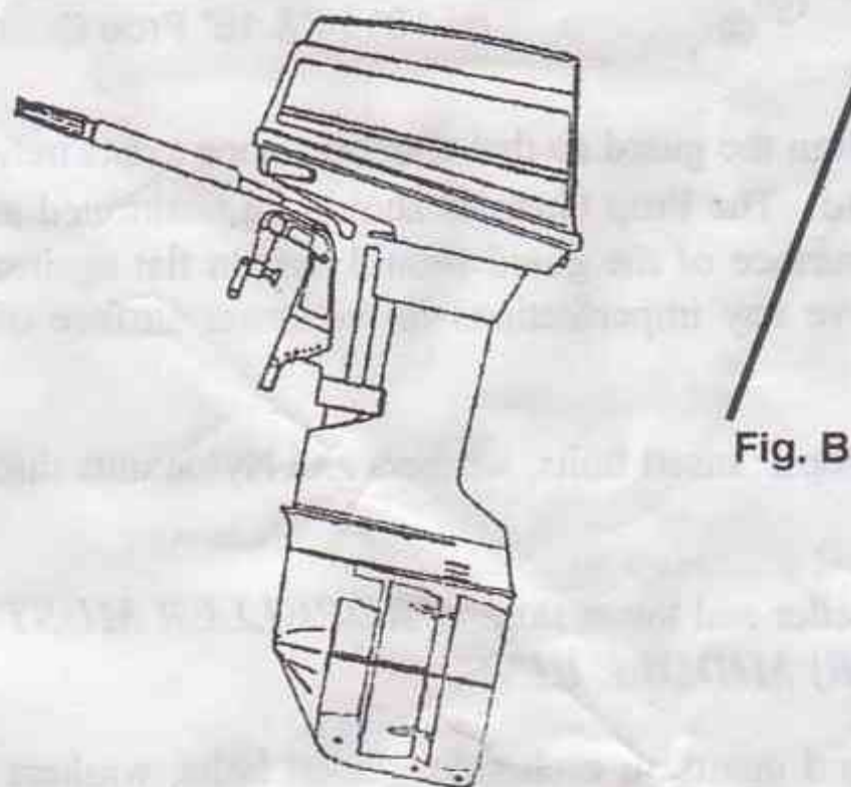
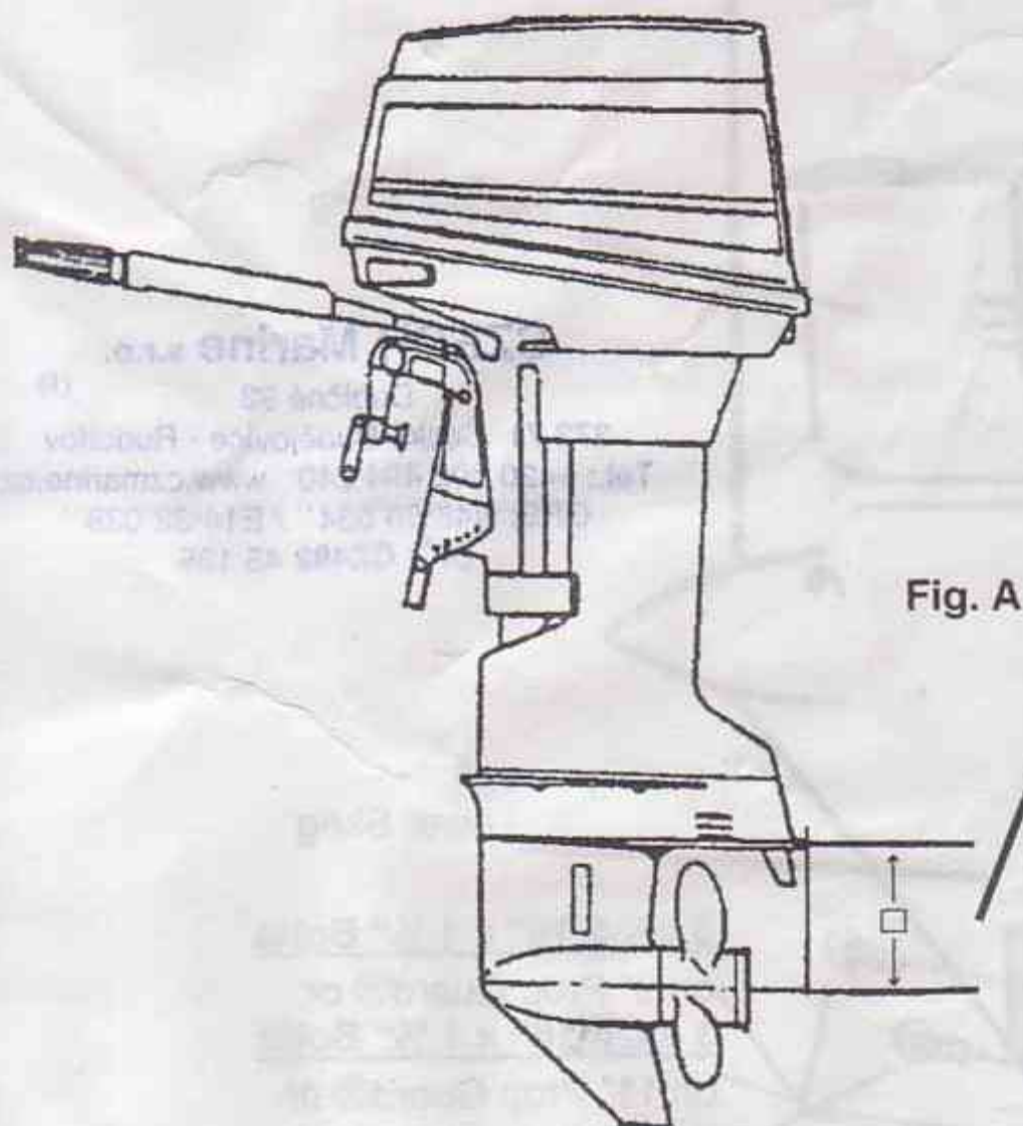

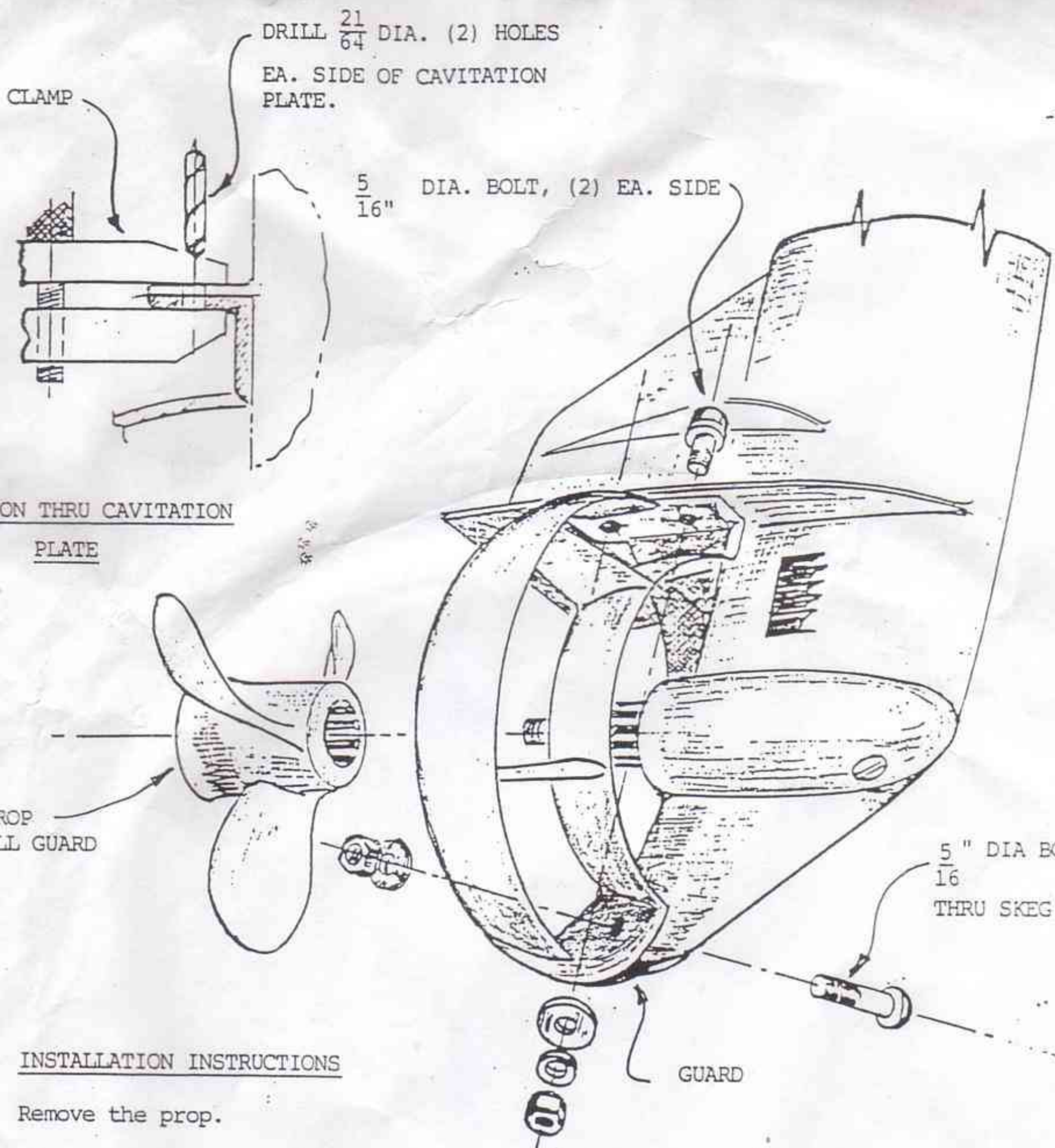

SECTION THRU CAVITATION PLATE

INSTALLATION INSTRUCTIONS

Remove the prop.

Place the guard on the underside of the cavitation plate. Align the guard so that equal clearance exists when the propeller is revolved inside the guard. The guard is to be located as far forward on the cavitation plate as possible. However, the mounting surface of the guard should remain flat with respect to the cavitation plate. Use a hand file to remove any imperfections in the lower surface of the cavitation plate and the lower skeg. Clamp the guard to the cavitation plate using C-Clamps.

On some motors the skeg may be too thick to fit between the guard ribs. File off only as much metal from both sides of the skeg as is necessary to make a snug fit between guard ribs.

Make certain that the guard is square with the cavitation plate, propeller and lower skeg.

Install the prop and check clearance when it is revolved inside the guard.



P.O. Box 630
Westcliffe, CO 81252
U.S.A

CZECH Marine s.r.o.

Dubičné 93 (1)
373 71 České Budějovice - Rudolfovo
Tel.: +420 602 494 240 www.czmarine.cz
GPS: N48°59'034" / E14°32'028"
DIČ: CZ482 45 135

Prop Guard®

Installation Instructions

Time required: About 25-30 minutes. Don't be in a hurry!

Tools needed: Drill, 5/16" bit, 1/2" box end or socket wrench, C-clamps or Grip clamps.

4 ea. 5/16" x 1" Bolts
on 9" & 11" PROP GUARD®
6 ea. 5/16" x 1" Bolts
on 13", 14" & 16" PROP
GUARD®

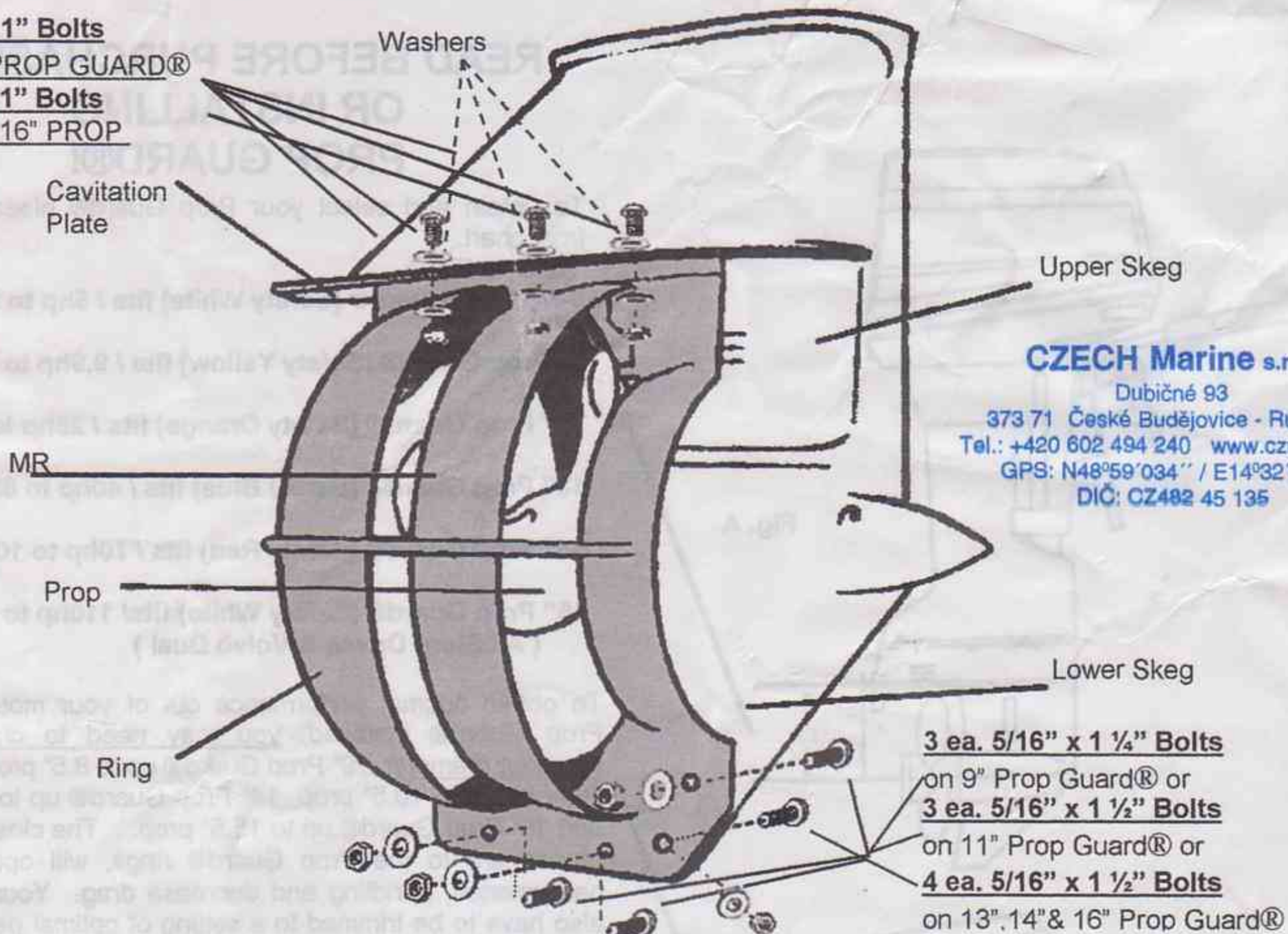

CZECH Marine s.r.o.
Dubičné 93 (1)
373 71 České Budějovice - Rudolfov
Tel.: +420 602 494 240 www.czmarine.c
GPS: N48°59'034" / E14°32'028"
DIČ: CZ482 45 135

1. Place the Prop Guard® on the underside of the cavitation plate. Align the guard so that equal distance exists between the guard and the prop when the propeller revolves inside the guard. The Prop Guard® should be positioned as far forward on the cavitation plate as possible. Note: the mounting surface of the guard should remain flat against the cavitation plate. The use of a hand file may be needed to remove any imperfections in the lower surface of the cavitation plate and the lower skeg.
2. Clamp the guard to the cavitation plate using C-clamps or Grip clamps. Insert bolts, washers and Nyloc nuts through bottom of pre-drilled holes at bottom of rings and loosely tighten.
3. Make certain that the guard is square with the cavitation plate, propeller and lower skeg. **PROPELLER MUST BE IN LINE WITH MIDDLE RING PER ILLUSTRATION (MR) MIDDLE RING.**
4. Drill 2 to 3 (see chart Above) holes through the cavitation plate and guard on each side. Insert bolts, washers and Nyloc nuts as illustrated and loosely tighten.
5. Drill 1 to 2 (see chart above) holes through lower skeg, per illustration. Insert bolt, washer and Nyloc nut, tighten securely. Now tighten all your bolts. **REMOVE CLAMPS !!!**
6. **EXTREMELY IMPORTANT: MAKE SURE YOUR MOTOR IS TRIMMED TO OBTAIN MAXIMUM PERFORMANCE OF YOUR PROP GUARD®.**

PROP GUARD MARINE, INC., P.O. Box 630, Westcliffe, CO 81252